



Portfolio

Phoebe Barron



01 Social Design

02 Commercial Staircase Design

03 Retail Design

Contents





Initial sketches

My final portfolio project focused on the re-design of an abandoned Arding & Hobbs department store to cater for a social need of my own choosing. My chosen need was the homeless community based in Milton Keynes. The design aimed to combat this social issue by providing necessary amenities and resources for the community, but to also disband the stigma surrounding this issue by bringing both the community of the homeless and of Milton Keynes together. The design also houses up to 5 permanent residents at one time.

The design focused on contrasting to the existing locations material and linear forms, by providing an organic and biophilic environment.

01 Social Design

A Forever Home



Exterior of cafe created with Revit, Enscape & Photoshop



Entrance to cafe created with Revit, Enscape & Photoshop



The concept, **Authentic Coalesce**, was inspired by the necessary means to create a genuine design for its residents. Influences from trauma informed design and biophilic design were also included, and are evident within key sketches and models.

Most noticeably, the experimentation with tree structure allowed for continuous biophilic influences within the design, as well as implementing various checkpoints throughout the design to act as a means of way finding and validation.



A series of models & sketches to help form my concept

Sketches & Modeling

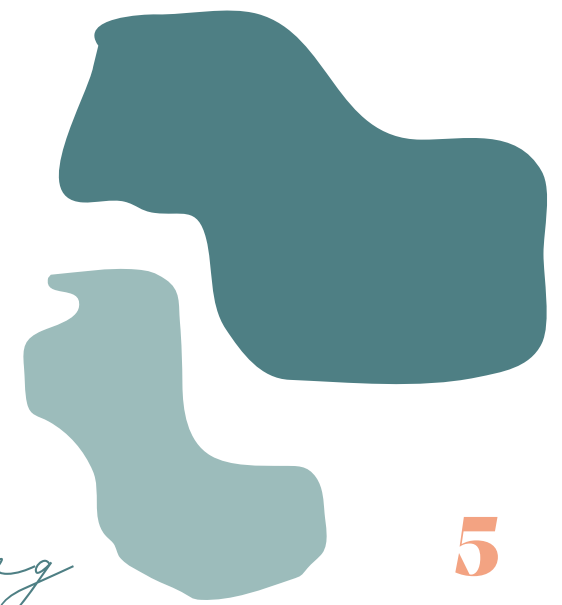



Close up images of my materials board



Resident hallway digital furniture board created in photoshop



Resident bedroom digital furniture board created in photoshop

Materials & Finishes

To keep consistency within the design, all materials and finishes were sourced with the intention of repeating throughout all levels of the design. The materials sourced were influenced by biophilia, but also the principles in Trauma Informed Design. A cool colour palette and materials with both acoustic and sensory stimulating properties were gathered. By doing this, it created familiarity, and evoked and calm and stress free design.

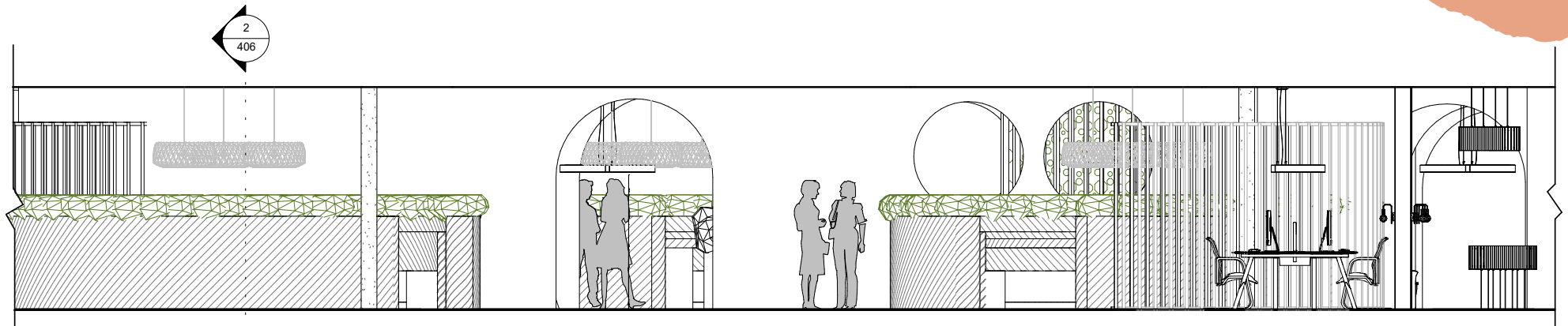

1 Third Floor Educational Space Section
1 : 50

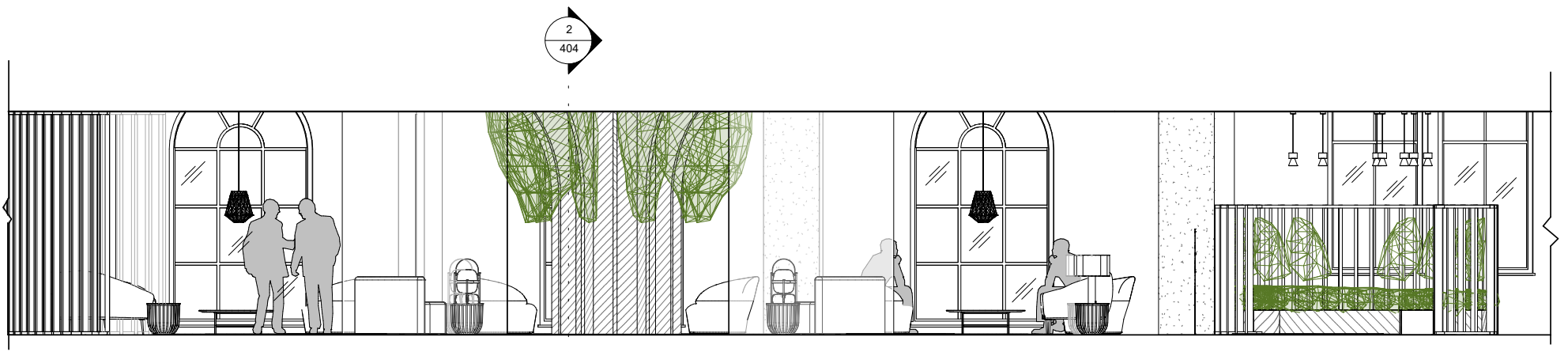

2 Third Floor Reading & Garden Section
1 : 50



Rendering of ground floor created in Revit & Enscape

The final design was spread over two levels, the compulsory ground floor, and the chosen third floor. The ground floor housed mostly public amenities, consisting of the large communal cafe, private resident entrance, as well as other amenities such as showers, hairdressers, and a clothing donation store.

The third floor consisted of mostly private amenities, consisting of a 5 private bedrooms for residents, a reading room, educational pods, napping rooms and therapy spaces, as well an arcade and cinema room, and a large dining and kitchen area..

The Final Design



Rendering of third floor created in Revit & Enscape



Rendering of ground floor donation store created in Revit, Enscape & Photoshop



Rendering of ground floor public entrance created in Revit, Enscape & Photoshop



Rendering of third floor dining seating created in Revit, Enscape & Photoshop



Rendering of third floor educational pods created in Revit, Enscape & Photoshop



Rendering of third floor reading room created in Revit, Enscape & Photoshop

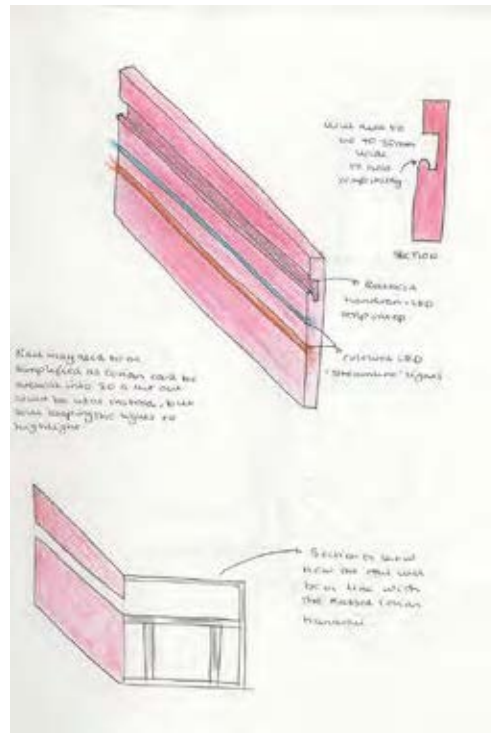
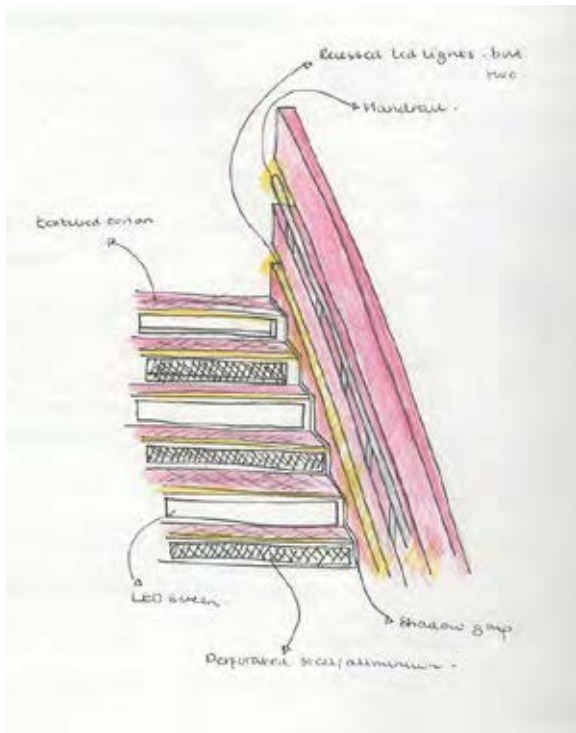

Initial sketches

The brief for the commercial staircase design was an extension of a previous project where we designed a retail space for the year 2040. The context of the previous project derived from shift in retail sector consumer behaviour from in-store presence to online dominance.

The concept 'Euphoric Synaesthesia', focuses on the play on words from the chosen skincare brand Drunk Elephant, with their playful approach to skincare, with their bright colour palette, humorous phrases and somewhat reminiscence of 90's rave culture. The design of the staircase will continue on this vein with the existing sensory distortion design.



02 Commercial Staircase Design

Drunk Elephant

Rendering of exterior staircase created in Revit, Enscape & Photoshop





Model of the staircase in its entirety, edited with photoshop



Modelling

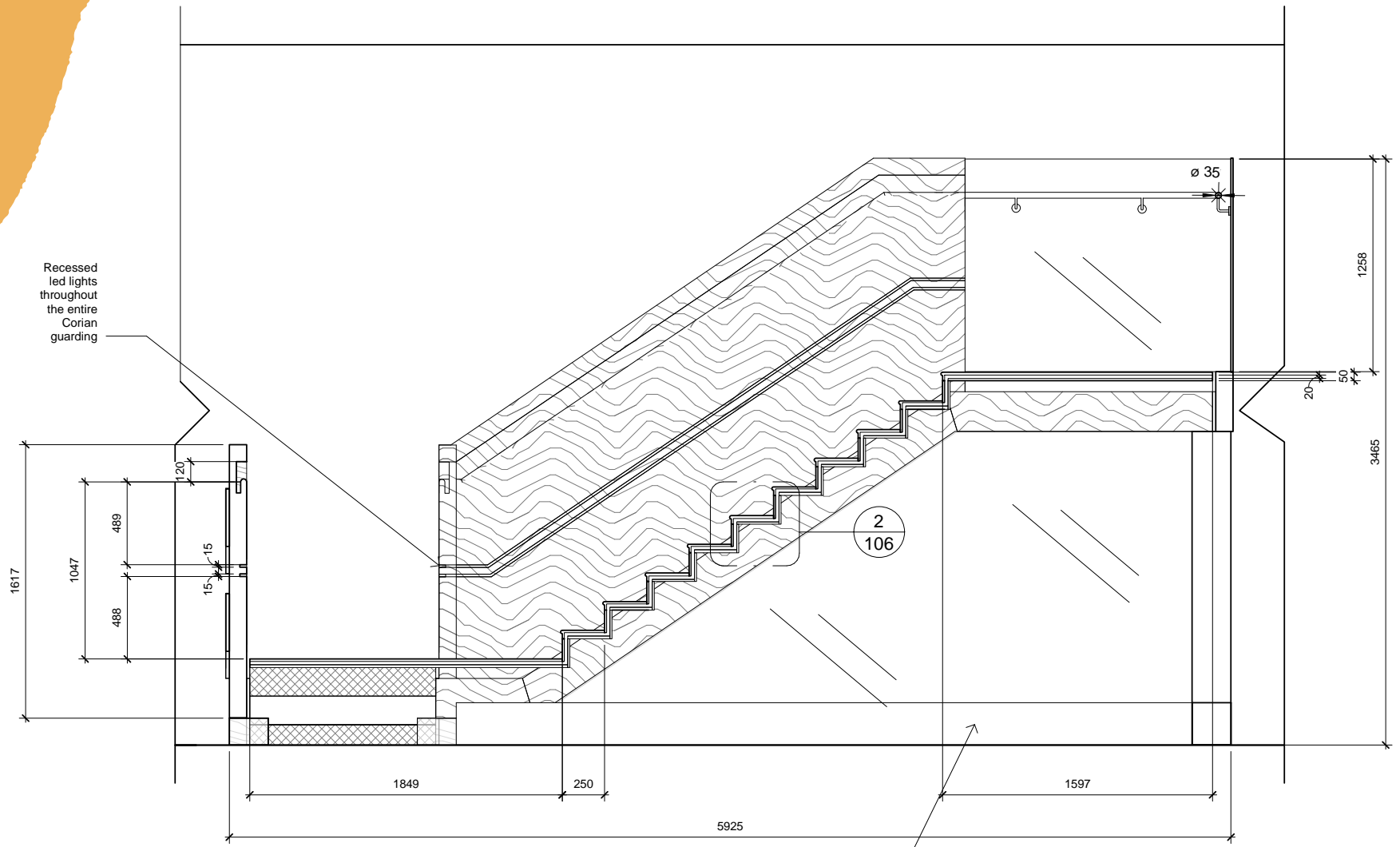

Seiger balustrade system for the support of the strengthened glass underneath

1 Cross Section
1 : 25

21 mm mirrored tiles adhered to the exterior of the Corian at 500 x 500mm

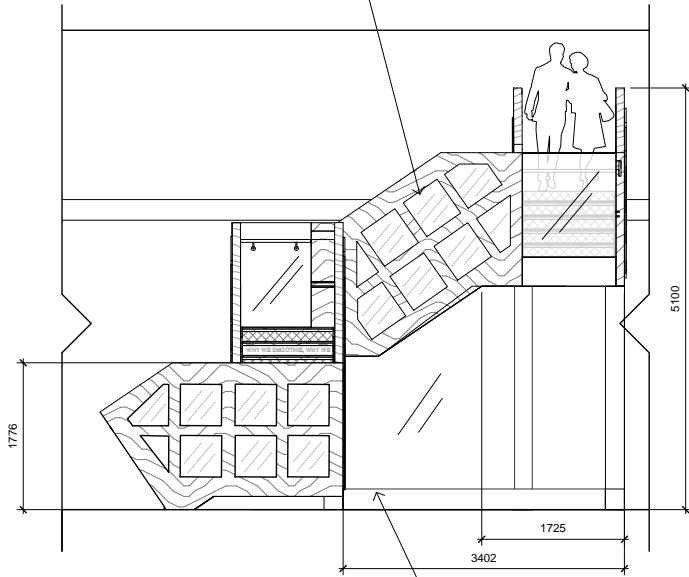

1 West Elevation
1 : 50

Strengthened Interlay Glass to support the underneath of the staircase at 230mm thickness.

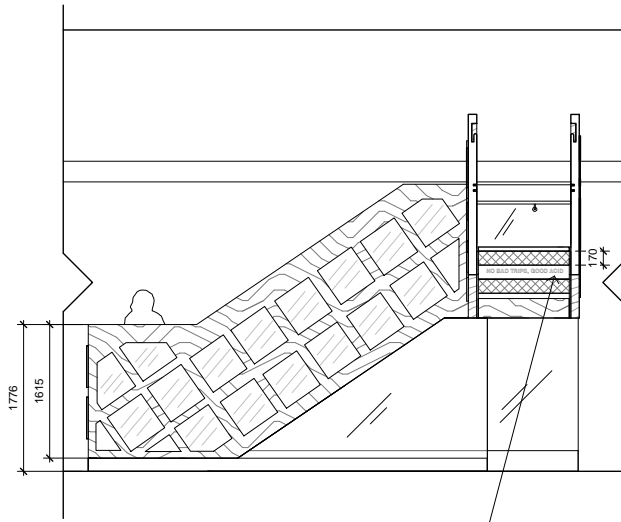

2 South Elevation & Section Cut at 3rd Run
1 : 50

Integrated LED Screens on every other riser showcasing running Drunk Elephant Slogans.

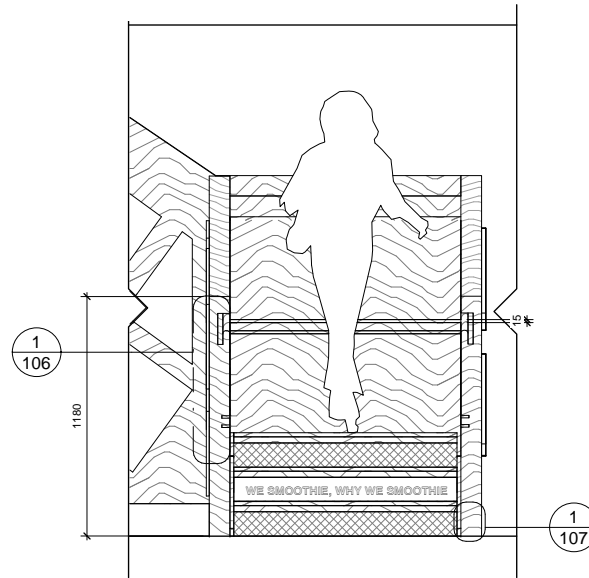

1 Longitude Basement Level
1 : 20

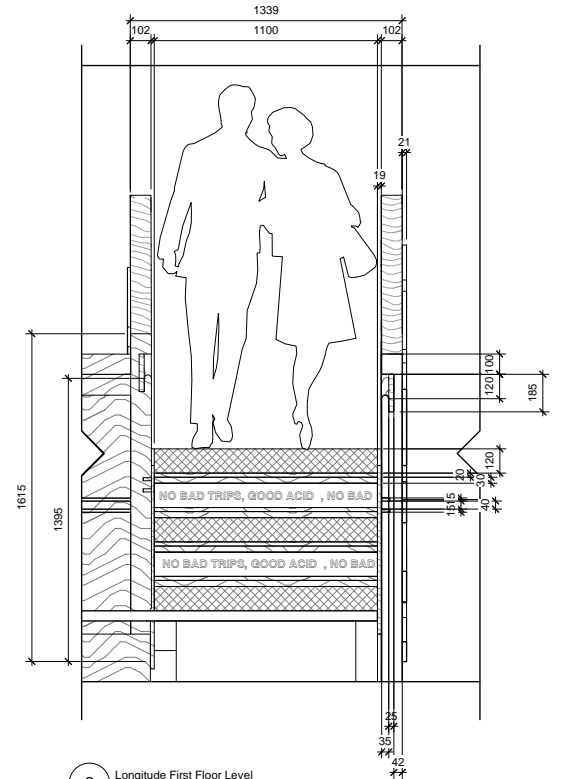

2 Longitude First Floor Level
1 : 20

Final Design

Hot pink was chosen as the main colour palette choice for the staircase due to one of the main colour components within Drunk Elephants colour palette, and was an effective contrasting colour amongst their existing colour palette.

With highly textured materials already within the existing design, it was important to continue with stimulating materialistic decisions. The primary material for the staircase was textured Corian®, chosen to evoke the rough texture of elephant skin, which is used for the treads, nosing and partial guarding, alongside perforated steel for the risers.

Strengthened inter lay glass are used for two corner guarding to act as stopping points when ascending or descending the staircase. Large mirror tiles used for the exterior of the staircase to contribute to the distortion effect of the design and to evoke the mosaic interpretation of elephant skin. Recessed led lights will also run below the handrail to create a streamline effect.

15



Rendering of entrance to basement via staircase created in Revit, Enscape and Photoshop

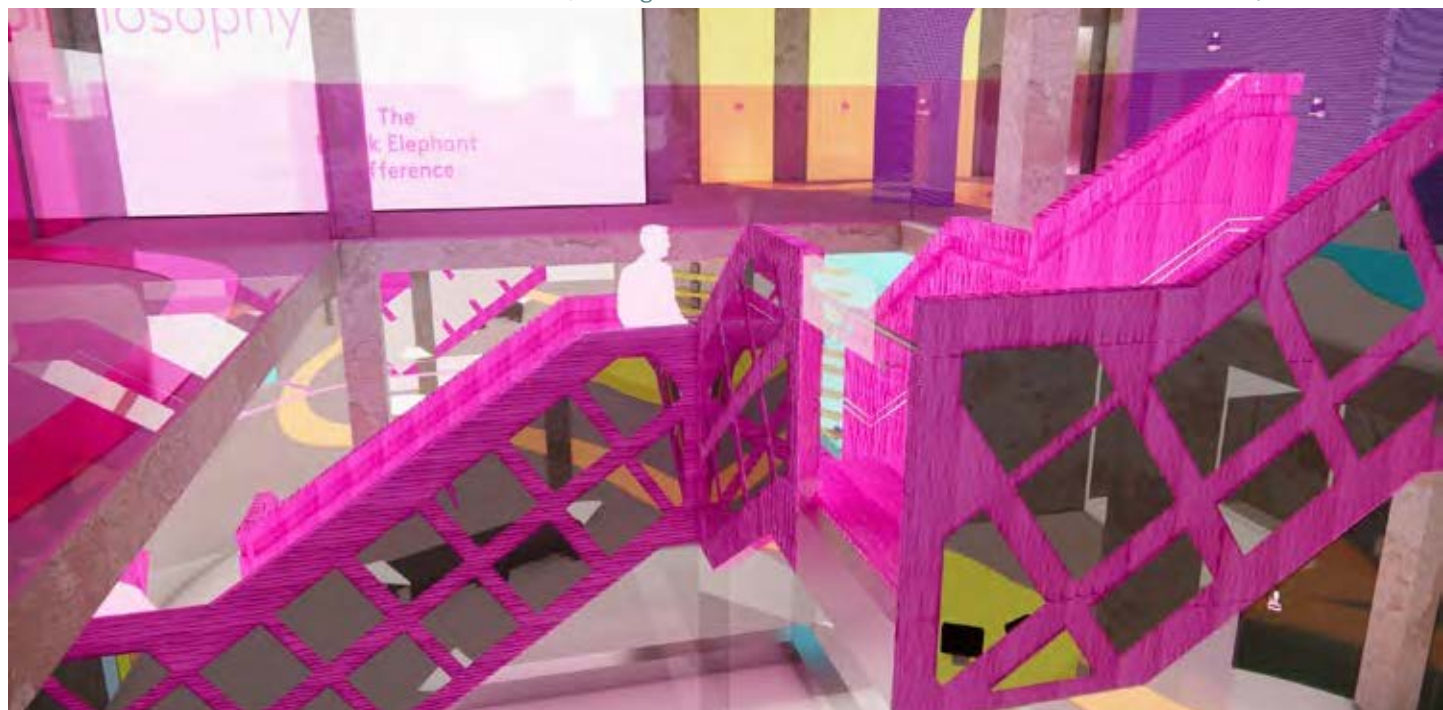

Rendering of exterior of staircase created in Revit, Enscape & Photoshop

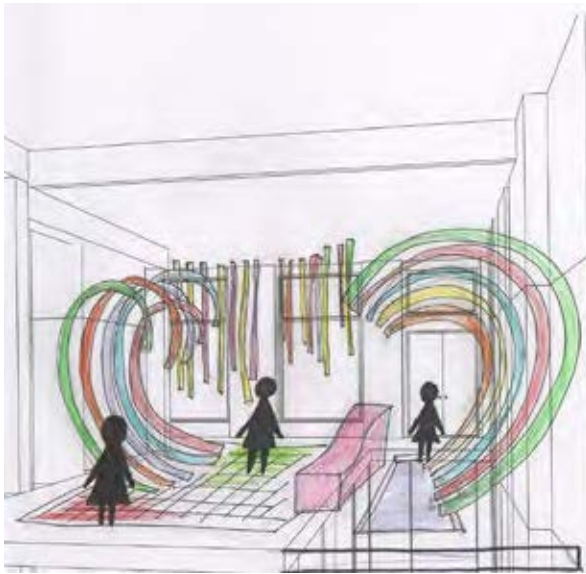

Initial sketches

The context for this project is derived from the shift in retail sector consumer behaviour from in-store presence to online dominance. The project focuses on the future of the retail sector and the expected behaviour of generational consumers in the year 2040. The design aims to create a unique and innovative store for the chosen client, Drunk Elephant.

The concept 'Euphoric Synaesthesia', focuses on the play on words within the marketing of the client, with their playful approach to skincare, bright colour palette, humorous phrases and somewhat reminiscence of 90's rave culture.

03 Retail Re-Imagined

Drunk Elephant



Rendering of entrance to store created in Revit, Enscape & Photoshop



Rendering of display counter created in Revit, Enscape & Photoshop



Experimental modelling

Modelling



Exterior of ground floor created in Revit

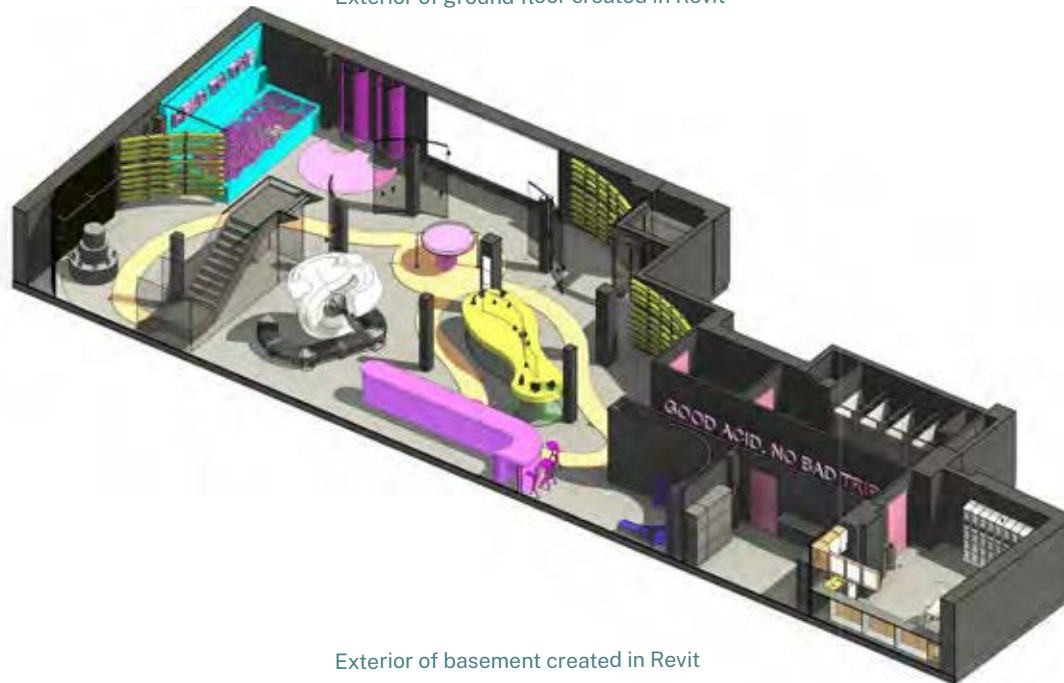

Exterior of basement created in Revit

The Final Design

As an introduction to the brand for consumers, the design had to instantly captivate through a range of sensory textures, colours and lighting. This allows consumers to understand what Drunk Elephant is all about, and to come to their own conclusions as to how they may delve into the remaining parts of the space.

The primary functions for the space on the ground floor consist of an introduction into the brand through the primary source of display, through various sensory materials. The various displays are communicated through wall displays, the entrance ordering table, and the walk through archway space.

To allow connection between the displays, the bestsellers, displayed through 'The Line', one of Drunk Elephant's witty phrases. Floor transitions will allow consumers to be lead to the different displays.



Basement display created in Revit, Enscape and Photoshop



Ground floor display created in Revit, Enscape and Photoshop



Basement display created in Revit, Enscape and Photoshop



Ground floor display created in Revit, Enscape and Photoshop





Thank You